

THESE DRAWINGS AND SPECIFICATIONS ARE THE SOLE PROPERTY OF ADVANCED CONNECTION TECHNOLOGY INC. AND SHALL NOT BE REPRODUCED, COPIED, OR USED IN ANY MANNER WITHOUT THE PRIOR WRITTEN CONSENT OF ADVANCED CONNECTION TECHNOLOGY INC. OR ITS AFFILIATED SUBSIDIARIES.

CAD FILE: S0200106A

REV.	DESCRIPTION	DWG		APPROVED	
		NAME	DATE	NAME	DATE
AA	RELEASED	Balon	2006/08/17	Hunter	2006/08/17
AB	ECN:DC0609036	Bite	2006/09/27	Hunter	2006/09/27
AC	ECN: DC0612019	Bite	2006/12/13	Hunter	2006/12/13

- ◆ Assembly dim.
- Functionally dim.
- Control dim.

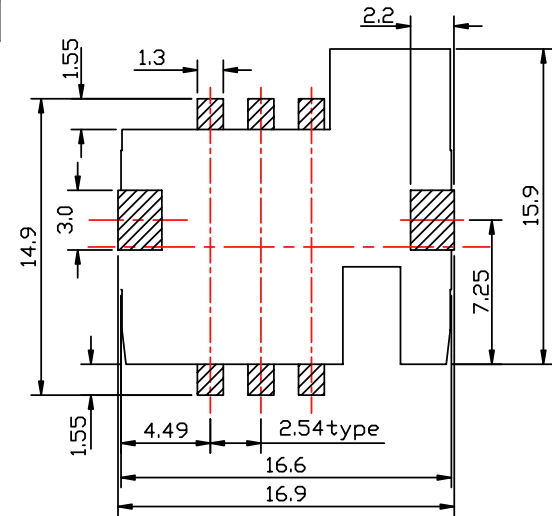
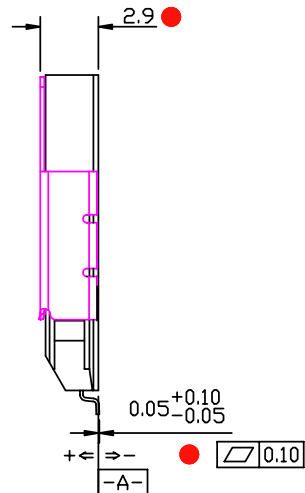
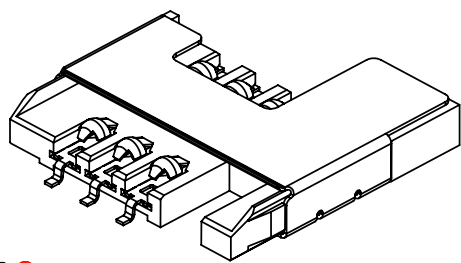

RECOMMENDED PCB LAYOUT
(GENERAL TOLERANCES : ±0.05)

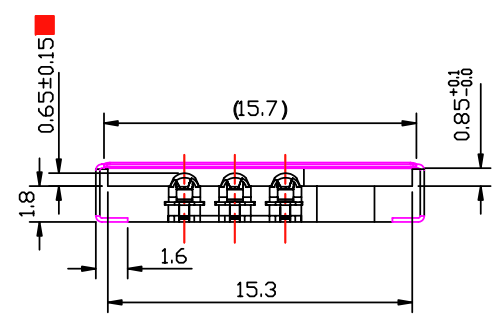
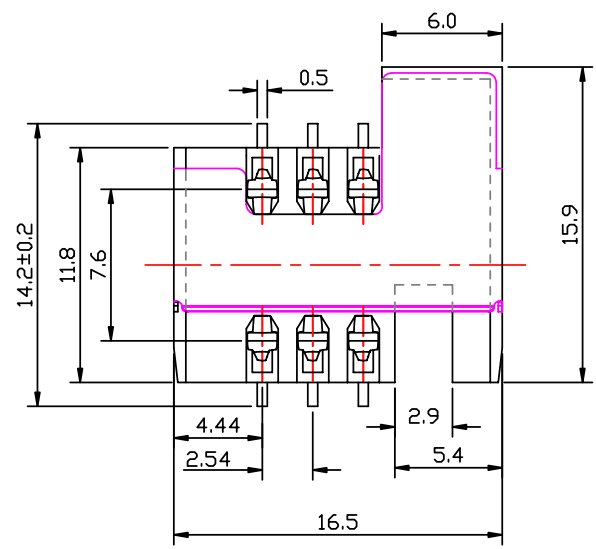

- Notes:
- Housing: High thermoplastic.
 - Contact: Copper Alloy.
Plating: Selected 15u" Au plating on contact area.
 - ▲ The Solder Area is Plated With Au(1~3u")
 - Under Layer is Plated With 50u" Nickel.
 - Cover: Stainless Steel
Plating: The Solder Area is Plated With Gold-flash
Under Layer is Plated With 50u" Nickel.

INTENDED USE: ACT		ACT Advanced Connection Technology Inc. TAIWAN, R.O.C. TEL: 886-2-88091080			
GENERAL DIMENSION		TITLE: Sim Card Conn. DIP, pin H=2.9mm		DRAWN: Bite	2006/12/13
XX±0.30	X.X±0.15	CHECKED: Knight		2006/12/13	
X±0.20	X.XX±0.10	DWG NO: 217-02001-06	REV. AC	APPROVED: Hunter	
UNIT: mm		SCALE: NONE	SHEET 1 OF 2	NAME	DATE

THESE DRAWINGS AND SPECIFICATIONS ARE THE SOLE PROPERTY OF ADVANCED CONNECTION TECHNOLOGY INC. AND SHALL NOT BE REPRODUCED, COPIED, OR USED IN ANY MANNER WITHOUT THE PRIOR WRITTEN CONSENT OF ADVANCED CONNECTION TECHNOLOGY INC. OR ITS AFFILIATED SUBSIDIARIES.

CAD FILE: S0200106b

REV.	DESCRIPTION	DWG		APPROVED	
		NAME	DATE	NAME	DATE
AA	RELEASED	Balon	2006/08/17	Hunter	2006/08/17
AB	ECN:DC0609036	Bite	2006/09/27	Hunter	2006/09/27
AC	ECN: DC0612019	Bite	12/13/2006	Hunter	12/13/2006

- △ AC
- ◆ Assembly dim.
- Functionally dim.
- Control dim.

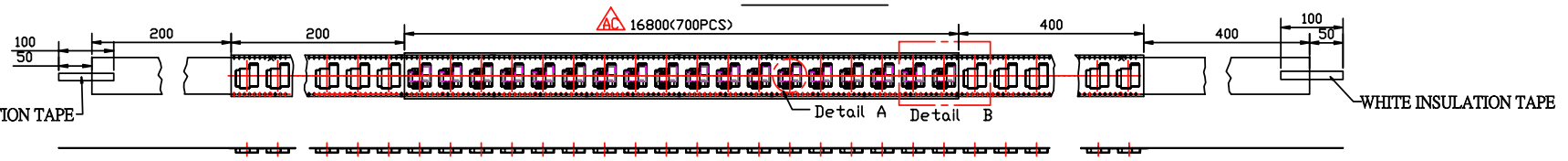
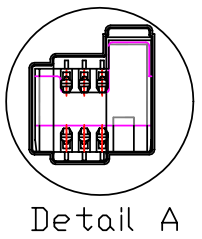
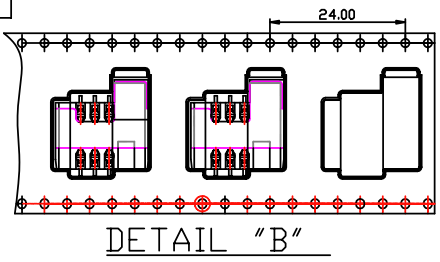

NOTE:
 ● 1. PACKING PREPARE LEADER AND EMPTY. DETAIL AS BELOW (UNIT:mm)

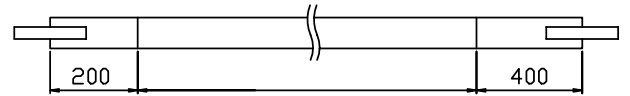

TAIL(EMPTY) WITH SIMCARD LEADER(EMPTY)

● 2. FORCE OF TEARING OFF TOP TAPE 15-80 gf.

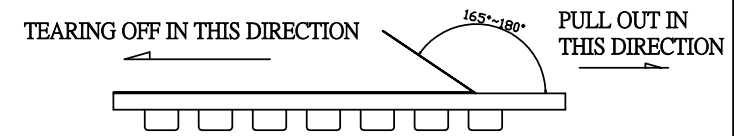

- 3. QUANTITY--PLASTIC REEL ABOUT 700 PCS. △ AC
- 4. PLEASE ATTACH QUALIFIED LABEL ACCORDING TO THIS DRAWING
- 5. EACH REEL NEEDS STICKING 3 PIECES INSULATION TAPE(L=10cm)

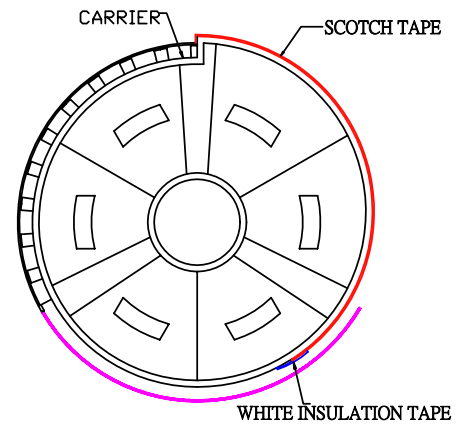
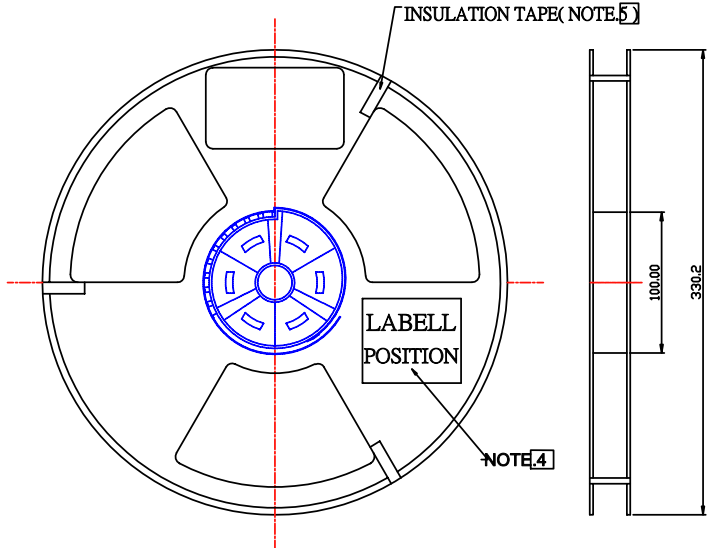

PACKAGE WAY

INTENDED USE: ENGRG		ACT Advanced Connection Technology Inc. TAIWAN, R.O.C. TEL: 886-2-88091080			
GENERAL DIMENSION		TITLE: Sim Card Conn. DIP, H=2.9mm		DRAWN: Bite	12/13/2006
XX±0.30	XX±0.15	DWG NO: 217-02001-06		CHECKED: Knight	12/13/2006
X±0.20	X.XX±0.10	REV: AC		APPROVED: Hunter	12/13/2006
UNIT: mm		SCALE: NONE	SHEET: 2 OF 2	NAME	DATE