

THESE DRAWINGS AND SPECIFICATIONS ARE THE SOLE PROPERTY OF ADVANCED CONNECTION TECHNOLOGY INC. AND SHALL NOT BE REPRODUCED, COPIED, OR USED IN ANY MANNER WITHOUT THE PRIOR WRITTEN CONSENT OF ADVANCED CONNECTION TECHNOLOGY INC. OR ITS AFFILIATED SUBSIDIARIES.

CAD FILE: S0400013a

REV.	DESCRIPTION	DWG		APPROVED	
		NAME	DATE	NAME	DATE
AA	RELEASED	S.D	10/31/2008	Venky	10/31/2008

AA

- 1 ■ Functionally dim.
- ◆ Assembly dim.
- Control dim.

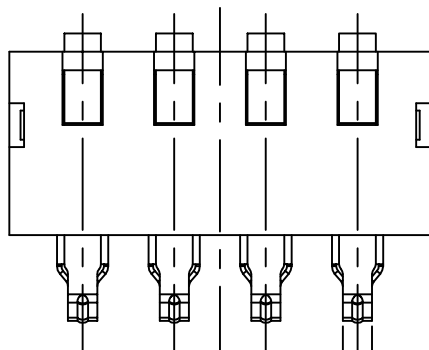

● Pitch=2.50 0.80

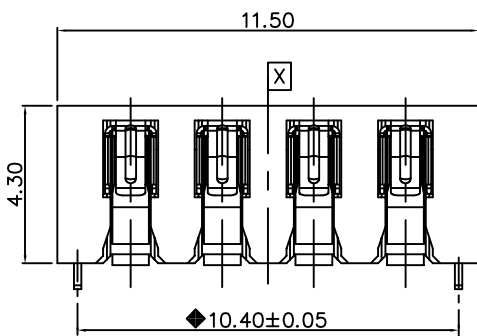

◆ 10.40±0.05

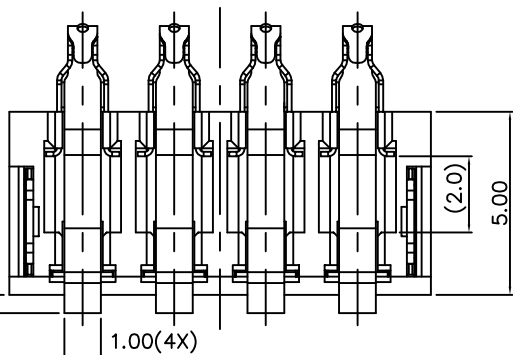

0.50

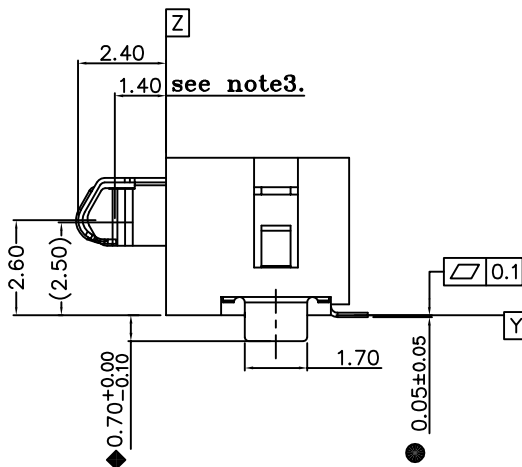
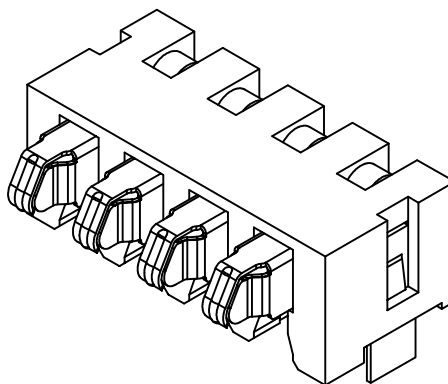

see note3.

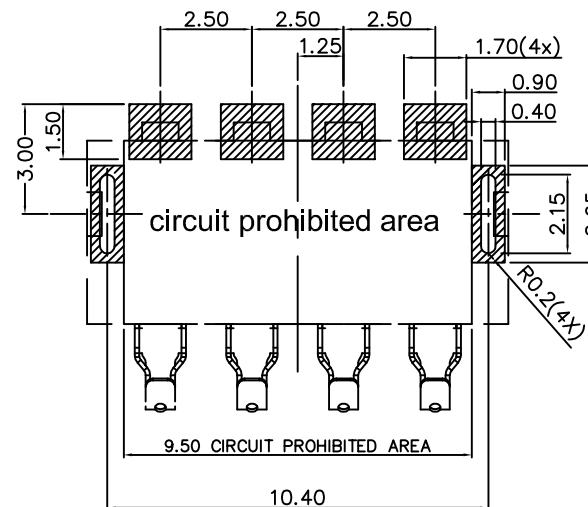

RECOMMENDED PCB LAYOUT TOLERANCE : ±0.05mm

Note

1. Material:
 - Housing: Thermal Plastic.
 - Contact: Copper alloy.T=0.12mm.
 - Plating: Ni Over all, Au (Contact area), Au (Soldering area).
 - Soldering Pin: Copper alloy.T=0.2mm.
 - Plating: Ni , Sn Over all.
- 2 COPLANARITY 0.1mm MAX.
3. CONTACT FORCE: 100±30gf MIN AT contact 1.4mm height.

Approval Signature

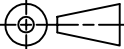
INTENDED USE: ACT		 Advanced Connection Technology TAIWAN TEL: 886-2-88091060			
GENERAL DIMENSION		TITLE: 4pin Battery Conn. Pitch=2.5mm, DIP		DRAWN: S.D	
XX±0.30	.X±0.15	DWG NO: 800-04000-13		10/31/2008	
X±0.20	.XX±0.10	REV: AA		CHECKED: Erin	
		APPROVED: Venky		10/31/2008	
		UNIT: mm	SCALE: NONE	SHEET: 1 OF 2	NAME: Venky

THESE DRAWINGS AND SPECIFICATIONS ARE THE SOLE PROPERTY OF ADVANCED CONNECTION TECHNOLOGY INC. AND SHALL NOT BE REPRODUCED, COPIED, OR USED IN ANY MANNER WITHOUT THE PRIOR WRITTEN CONSENT OF ADVANCED CONNECTION TECHNOLOGY INC. OR ITS AFFILIATED SUBSIDIARIES.

CAD FILE: S0400013b

REV.	DESCRIPTION	DWG		APPROVED	
		NAME	DATE	NAME	DATE
AA	RELEASED	S.D	10/31/2008	Venky	10/31/2008



- 功能
- ◆ 装配
- 控制

1
2
3
4
5

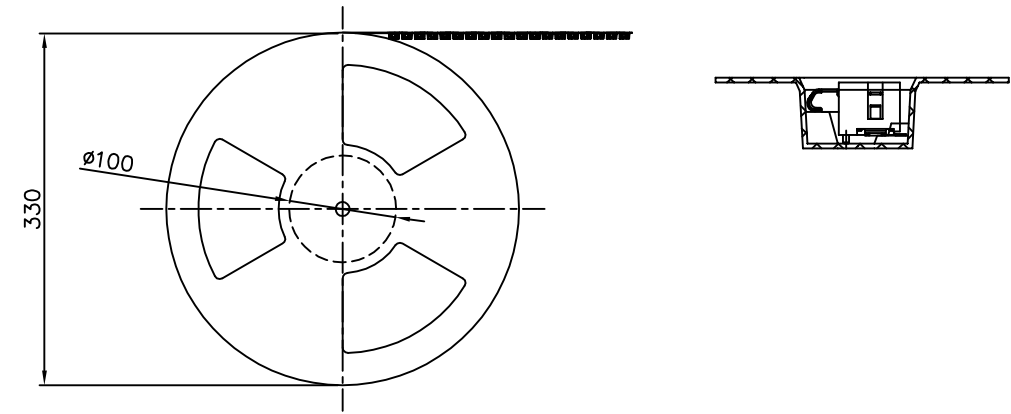
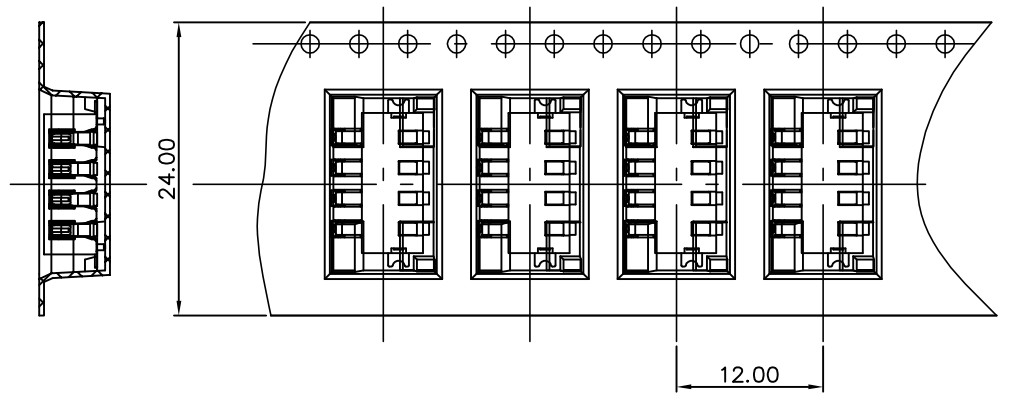

Note

- 4. PACKING PREPARE LEADER AND EMPTY.

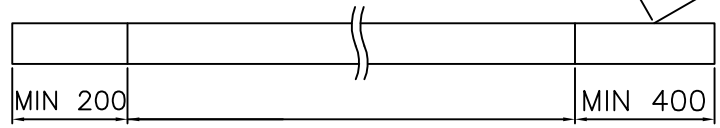
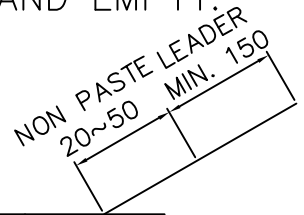

TAIL(EMPTY) WITH CONNECTOR LEADER(EMPTY)

- 5. FORCE OF TEARING OFF TOP TAPE 20~60 gf

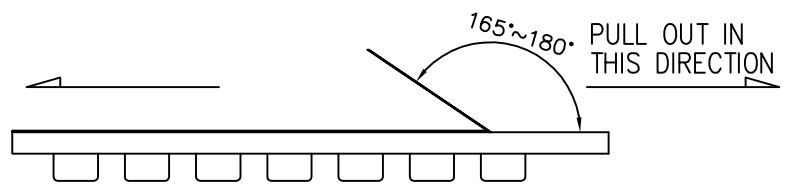

- 6. EDGE OF ROLLING UP SHOULD BE ADHERED THE TOP COVER TAPE TO THE SIDE OF RELL AN ADHENSIVE TAPE.
- 7. TOP COVER TAPE SHOULD BE LIMITED IN AREA OF PLASTIC TAPE.
- 8. PLASTIC REEL ---DIM A ϕ 330 DIM B ϕ 100.
- 9. QUANTITY----PLASTIC REEL ABOUT 800 PCS.
- 10. CARRIER TAPE COLOR : TRANSPARENT.

INTENDED USE: ACT		Advanced Connection Technology TAIWAN TEL: 886-2-88091060			
GENERAL DIMENSION		TITLE: 4pin Battery Conn. Pitch=2.5mm, DIP		DRAWN: S.D 10/31/2008	
XX±0.15	.X±0.07	DWG NO: 800-04000-13		CHECKED: Erin 10/31/2008	
X±0.10	.XX±0.03	REV: AA		APPROVED: Venky 10/31/2008	
		UNIT: mm	SCALE: NONE	SHEET 2 OF 2	NAME DATE