

THESE DRAWINGS AND SPECIFICATIONS ARE THE SOLE PROPERTY OF ADVANCED CONNECTION TECHNOLOGY INC. AND SHALL NOT BE REPRODUCED, COPIED, OR USED IN ANY MANNER WITHOUT THE PRIOR WRITTEN CONSENT OF ADVANCED CONNECTION TECHNOLOGY INC. OR ITS AFFILIATED SUBSIDIARIES.

CAD FILE: S1000101A

REV.	DESCRIPTION	DWG		APPROVED	
		NAME	DATE	NAME	DATE
AA	RELEASED	Janice	04/17/2007	Venky	04/17/2007
AB	DC0706020	Janice	06/12/2007	Venky	06/12/2007

- 1 ◆ Assembly dim.
- 2 ■ Functionally dim.
- 3 ● Control dim.

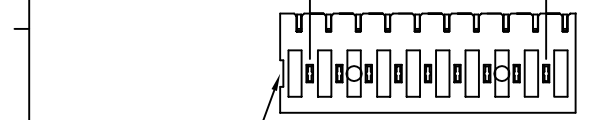
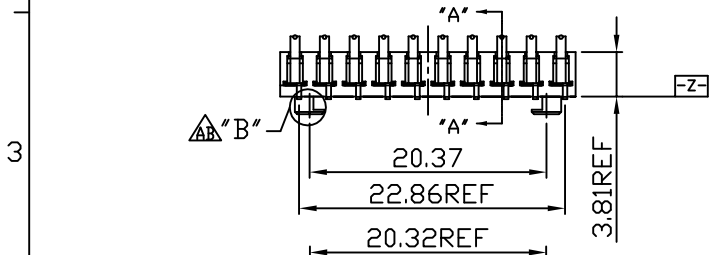
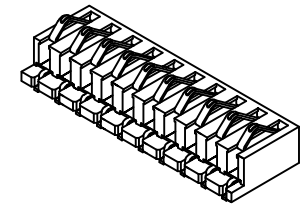
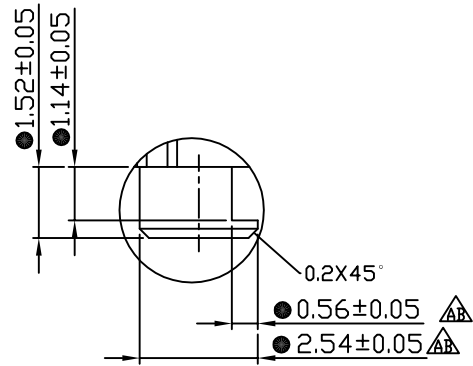
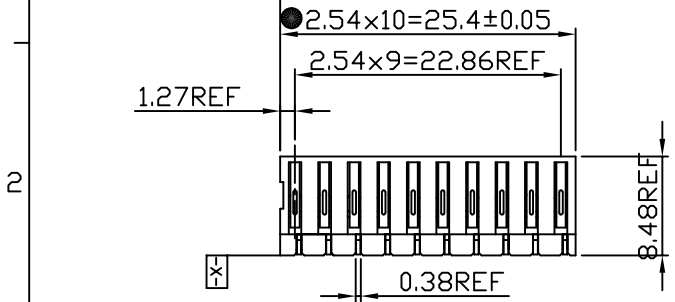

(NOTE 7.)

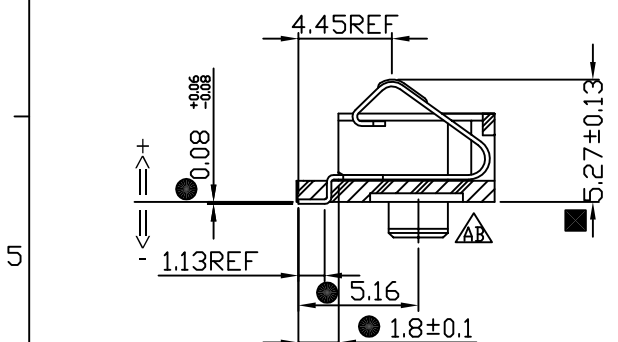

SECTION "A"-"A" 2:1

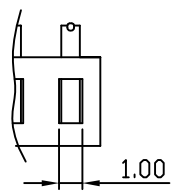

NOTES:

1. MATERIAL, HOUSING: LCP, UL94V-0, BLACK.
CONTACT: PHOSPHOR BRONZE.
2. FINISH, CONTACT: GOLD 3u" ON CONTACT AREA,
Sn ON SOLDERING AREA, Ni ALL OVER.
3. MAX ALLOWABLE BOW: TOP/BOTTOM: 0.10mm
SIDE/SIDE: 0.10mm
4. ALL IDENTIFICATION MARKS SHALL NOT APPEAR ON SURFACE A
5. PLEASE PUT LOT DATE, QUANTITY AND CUSTOMER P/N ON THE OUT CARTON
6. CUSTOMER P/N: ASP-129309-01
7. THE GATE CAN BE EITHER IN THE RIGHT SIDE OR LEFT SIDE. AND THE DEPTH OF IT SHOULD BE 0.254mm
8. BURR ALLOWANCE : 0.038MAX.
9. MINIMUM PUSHOUT FORCE : 1LB
10. IF THERE ARE MORE THAN ONE P/N IN A BOX, PLEASE SEPARATE THE DIFFERENT PARTS IN THE DIFFERENT BAGS.
11. PLEASE PUT 5PCS SAMPLE FROM EVERY CAVITY IN A SEPERATE TUBE & DON'T WRAP THIS TUBE.
12. PLEASE PUT THE LABEL THAT HAS CUSTOMER P/N ON EACH TUBE.

Approval Signature

INTENDED USE: +USSAM		ACT Advanced Connection Technology Inc. TAIWAN, R.O.C. TEL: 886-2-88091060			
GENERAL DIMENSION		TITLE: 10pin SIB A'ssy with solder lock "G" SINGLE INTERFACE BEAM(LC)		DRAWN: Janice 06/12/2007	
XX±0.25	X.X±0.15	DWG NO: 800-10001-01		CHECKED: Howard 06/12/2007	
X±0.20	.XX±0.10			APPROVED: Venky 06/12/2007	
UNIT: mm		SCALE: NONE		SHEET 1 OF 2	
		NAME		DATE	

THESE DRAWINGS AND SPECIFICATIONS ARE THE SOLE PROPERTY OF ADVANCED CONNECTION TECHNOLOGY INC. AND SHALL NOT BE REPRODUCED, COPIED, OR USED IN ANY MANNER WITHOUT THE PRIOR WRITTEN CONSENT OF ADVANCED CONNECTION TECHNOLOGY INC. OR ITS AFFILIATED SUBSIDIARIES.

CAD FILE: S1000101B

REV.	DESCRIPTION	DWG		APPROVED	
		NAME	DATE	NAME	DATE
AA	RELEASED	Janice	04/17/2007	Venky	04/17/2007
AB	DC0706020	Janice	06/12/2007	Venky	06/12/2007

△△

- 1 ◆ Assembly dim.
- 2 ■ Functionally dim.
- 3 ● Control dim.

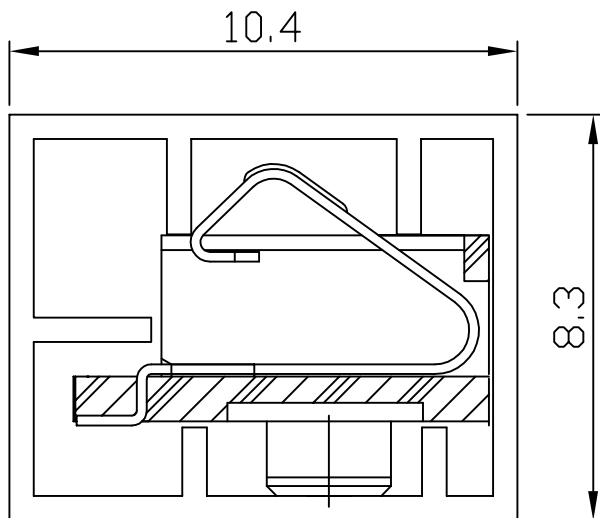
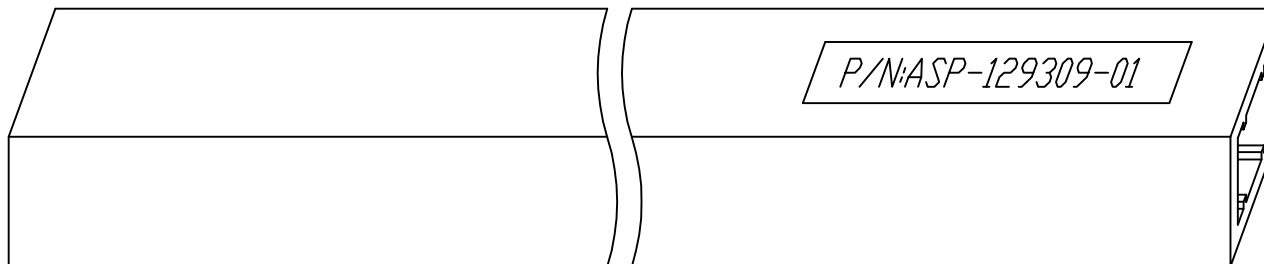

NOTES:

1. THICKNESS OF MATERIAL >0.5mm
2. LENGTH :56cm
3. 20 PCS/TUBE

Approval Signature

INTENDED USE: +USSAM		ACT Advanced Connection Technology Inc. TAIWAN, R.O.C. TEL: 886-2-88091080			
GENERAL DIMENSION		TITLE: 10pin SIB A'ssy with solder lock "G" SINGLE INTERFACE BEAM(LC)		DRAWN: Janice 06/12/2007	
XX±0.25	X.X±0.15	DWG NO: 800-10001-01		CHECKED: Howard 06/12/2007	
X±0.20	.XX±0.10	REV. AB		APPROVED: Venky 06/12/2007	
UNIT: mm		SCALE: NONE		SHEET 2 OF 2	
NAME		DATE			